

HALUX N30-1 P F1

TECHNICAL DATA	
FITTED WITH	1 × LED module
LUMINOUS POWER	30 000 lux / 0.5 m *
LIGHTING FIELD 0.5 m	Ø 18 cm (7.1 in.) *
COLOR RENDERING INDEX	CRI > 93
COLOR TEMPERATURE	4 400 K *
OPERATION EQUIPMENT	Plug-in power supply
VOLTAGE	100-240 V; 50/60 Hz
CORD LENGTH	1.7 m (5.6 ft.)
LUMINAIRE BODY	Polycarbonate (PC) & acrylonitrile butadiene styrene copolymer (ABS)
WEIGHT (NET)	1.1 kg (2.4 lbs)
POWER CONSUMPTION	8 W
USAGE	Push button on light head
BALANCE OF ARTICULATION JOINTS	Friction
CLASS OF PROTECTION	II
PROTECTION RATING	IP 20
STANDARDS MET	EN 60601-1, EN 60601-2-41
SPECIAL FEATURES	Continuously dimmable, maintenance-free, spring arm
MOUNTING	Mounting pin (Ø 16 mm)
ACCESSORIES	Rolling floor stand, rail mount with removal guard, table clamp with removal guard, universal mount with removal guard, extension arm with removal guard, wall mount with removal guard
ORDER NUMBER	D15.994.000-00806677 - pure white - EU, UK, US, AUS

EXAMINATION LIGHTS



LIGHT DISTRIBUTION

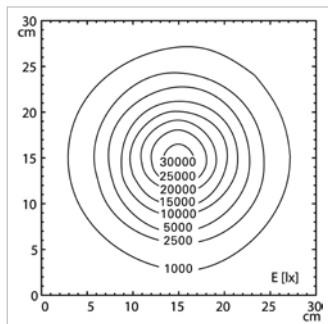
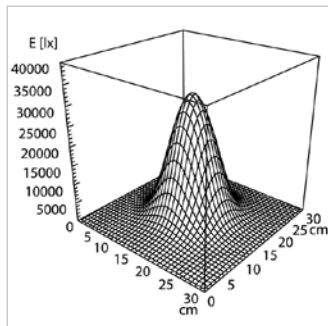

TECHNICAL DRAWING

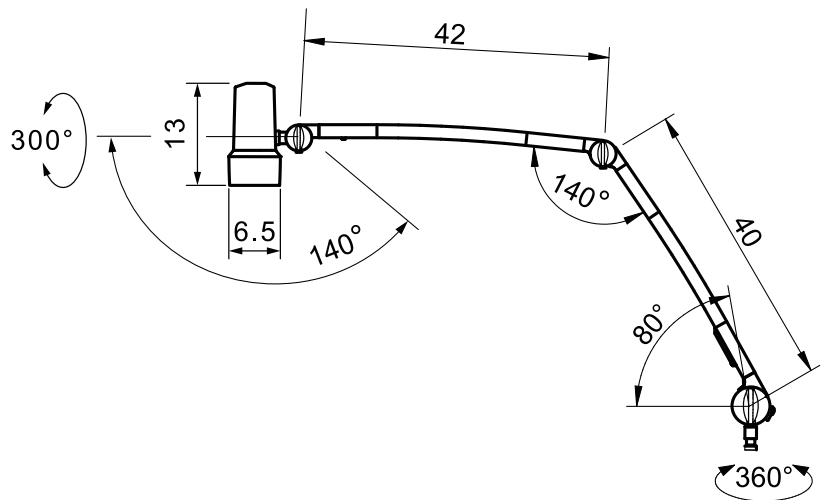

HALUX N30-1 P SGV Gyn

TECHNICAL DATA

FITTED WITH	1 × LED module
LUMINOUS POWER	30 000 lux / 0.5 m *
LIGHTING FIELD 0.5 m	Ø 18 cm (7.1 in.) *
COLOR RENDERING INDEX	CRI > 93
COLOR TEMPERATURE	4 400 K *
OPERATION EQUIPMENT	Plug-in power supply
VOLTAGE	100-240 V; 50/60 Hz
CORD LENGTH	3.0 m (9.8 ft.)
LUMINAIRE BODY	Polycarbonate (PC) & acrylonitrile butadiene styrene copolymer (ABS)
WEIGHT (NET)	1.3 kg
POWER CONSUMPTION	8 W
USAGE	Push button on light head
BALANCE OF ARTICULATION JOINTS	Friction
CLASS OF PROTECTION	II
PROTECTION RATING	IP 20
STANDARDS MET	EN 60601-1, EN 60601-2-41
SPECIAL FEATURES	Dimmable, maintenance-free, joint at the foot. Rail fastening with removal protection and brake function
MOUNTING	Mounting pin (Ø 16 mm)
ORDER NUMBER	D16.156.000-00809567 - pure white - EU, UK, US, AUS

EXAMINATION LIGHTS



LIGHT DISTRIBUTION

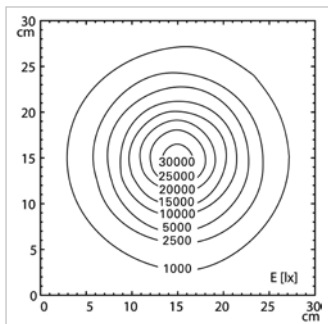
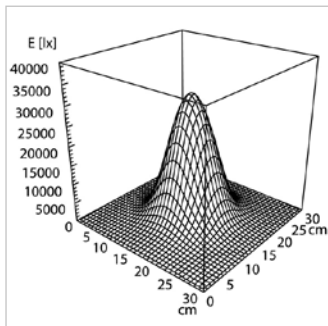

TECHNICAL DRAWING

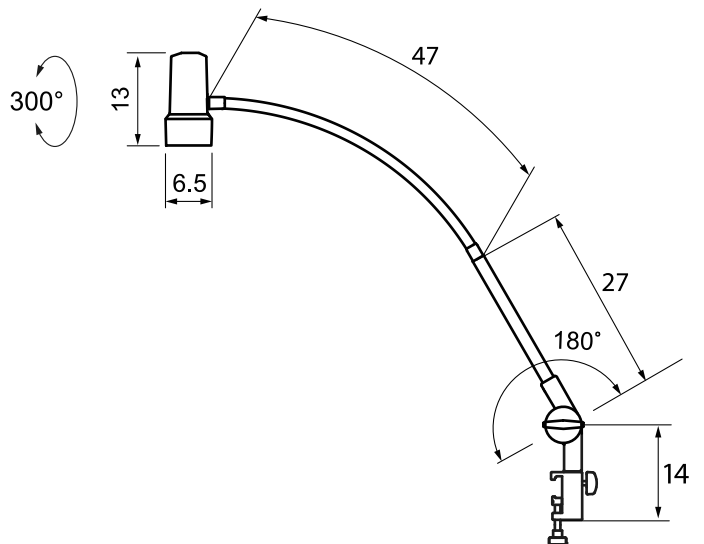

HALUX N30-1 P SG

TECHNICAL DATA

FITTED WITH	1 × LED module
LUMINOUS POWER	30 000 lux / 0.5 m *
LIGHTING FIELD 0.5 m	Ø 18 cm (7.1 in.) *
COLOR RENDERING INDEX	CRI > 93
COLOR TEMPERATURE	4 400 K *
OPERATION EQUIPMENT	Plug-in power supply
VOLTAGE	100-240 V; 50/60 Hz
CORD LENGTH	1.7 m (5.6 ft.)
LUMINAIRE BODY	Polycarbonate (PC) & acrylonitrile butadiene styrene copolymer (ABS)
WEIGHT (NET)	1.6 kg (3.5 lbs.)
POWER CONSUMPTION	8 W
USAGE	Push button on light head
BALANCE OF ARTICULATION JOINTS	Friction
CLASS OF PROTECTION	II
PROTECTION RATING	IP 20
STANDARDS MET	EN 60601-1, EN 60601-2-41
SPECIAL FEATURES	Continuously dimmable, maintenance-free, joint at the foot
MOUNTING	Mounting pin (Ø 16 mm)
ACCESSORIES	Rolling floor stand, rail mounting with removal guard, table clamp with removal guard, universal mount with removal guard, extension arm with removal guard, wall mount with removal guard

EXAMINATION LIGHTS



	connection horizontal	connection vertical	dimmable	Order No.
HALUX N30-1 P SGV		x	x	D15.992.000-00806675 - pure white - EU, UK, US, AUS
HALUX N30-1 P SGH	x		x	D15.993.000-00806676 - pure white - EU, UK, US, AUS

LIGHT DISTRIBUTION

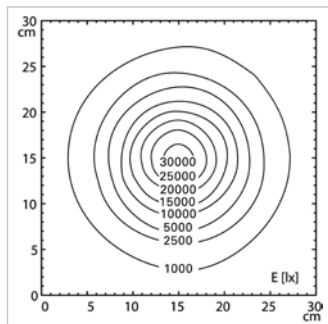
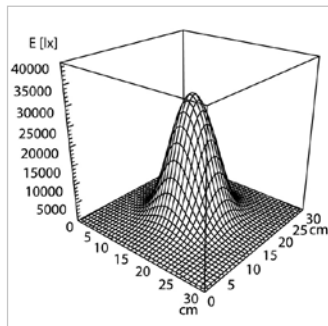

TECHNICAL DRAWING

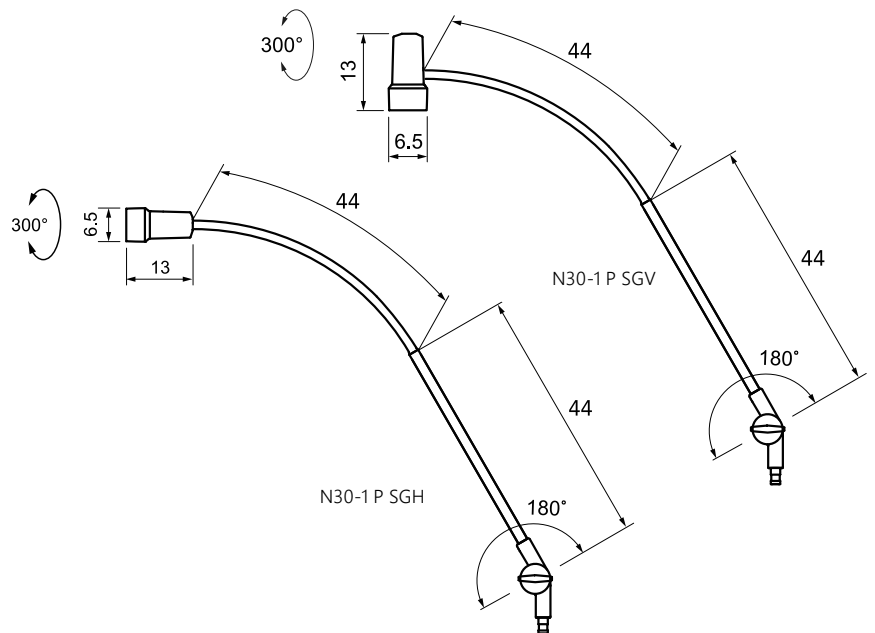

HALUX N30-1 P S

TECHNICAL DATA

FITTED WITH	1 × LED module
LUMINOUS POWER	30 000 lux / 0.5 m *
LIGHTING FIELD 0.5 m	Ø 18 cm (7.1 in.) *
COLOR RENDERING INDEX	CRI > 93
COLOR TEMPERATURE	4 400 K *
OPERATION EQUIPMENT	Plug-in power supply
VOLTAGE	100-240 V; 50/60 Hz
CORD LENGTH	1.7 m (5.6 ft.)
LUMINAIRE BODY	Polycarbonate (PC) & acrylonitrile butadiene styrene copolymer (ABS)
WEIGHT (NET)	1.3 kg (2.9 lbs)
POWER CONSUMPTION	8 W
USAGE	Push button on light head
CLASS OF PROTECTION	II
PROTECTION RATING	IP 20
STANDARDS MET	EN 60601-1, EN 60601-2-41
SPECIAL FEATURES	Continuously dimmable, maintenance-free
MOUNTING	Mounting pin (Ø 16 mm)
ACCESSORIES	Rolling floor stand, rail mount with removal guard, table clamp with removal guard, universal mount with removal guard, extension arm with removal guard, wall mount with removal guard

EXAMINATION LIGHTS



	connection horizontal	connection vertical	dimmable	Order No.
HALUX N30-1 P SV		x	x	D15.990.000-00806673 - pure white - EU, UK, US, AUS
HALUX N30-1 P SH	x		x	D15.991.000-00806674 - pure white- EU, UK, US, AUS

LIGHT DISTRIBUTION

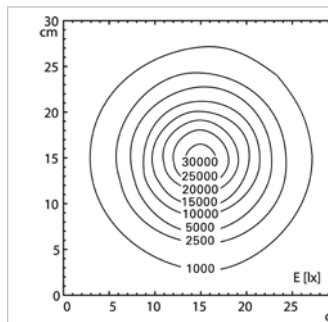
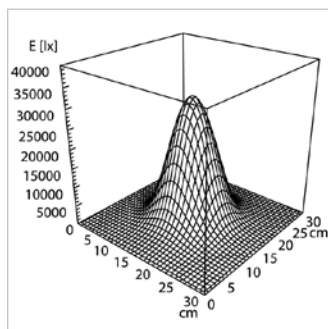

TECHNICAL DRAWING

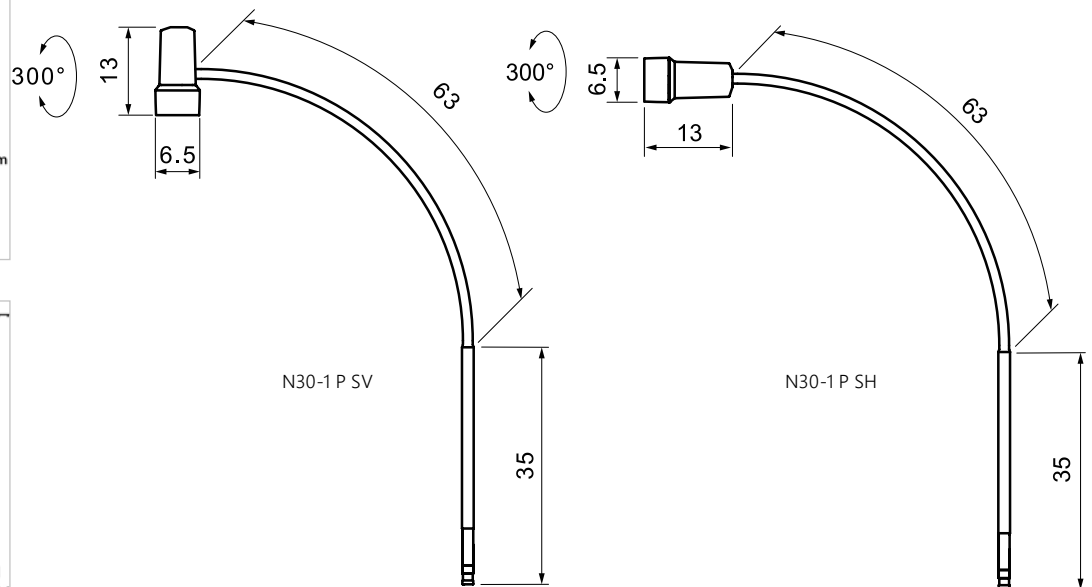

HALUX N30-1 F

TECHNICAL DATA	
FITTED WITH	1 x LED module
LUMINOUS POWER	30 000 Lux / 0,5 m *
LIGHTING FIELD 0.5 m	ø 18 cm*
COLOR RENDERING INDEX	CRI > 93
COLOR TEMPERATURE	4 400 K *
OPERATION EQUIPMENT	Plug-in power supply
VOLTAGE	100-240 V; 50/60 Hz
CORD LENGTH	2 m
LUMINAIRE BODY	Polycarbonate (PC) & acrylonitrile butadiene styrene copolymer (ABS)
WEIGHT (NET)	4,4 kg
POWER CONSUMPTION	8 W
USAGE	Push button on light head
CLASS OF PROTECTION	II
PROTECTION RATING	IP 20
STANDARDS MET	EN 60601-1, EN 60601-2-41
SPECIAL FEATURES	Continuously dimmable, maintenance-free
MOUNTING	Roller stand
ORDER NUMBER	D16.064.000-00808869

EXAMINATION LIGHTS



LIGHT DISTRIBUTION

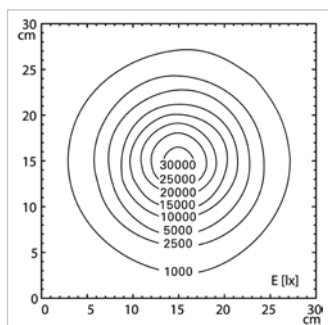
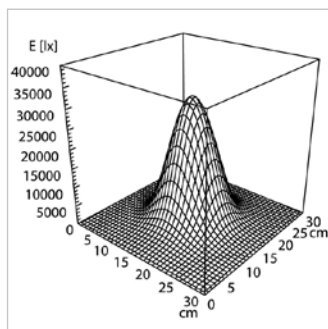

TECHNICAL DRAWING

